

1 Product Description

1.1. Features

The isolated analog input-/output board IPC/AI4VD-101E, AI4VT-101E is used for the input of analog process signals. The boards IPC/ AI4VD-101E and IPC/ AI4VT-101E are functionally identical, they only differ in the connector type, DSUB-9 for AI4VD, terminal block for AI4VT (see technical data section).

The block diagram of the board is shown in Fig. 1.

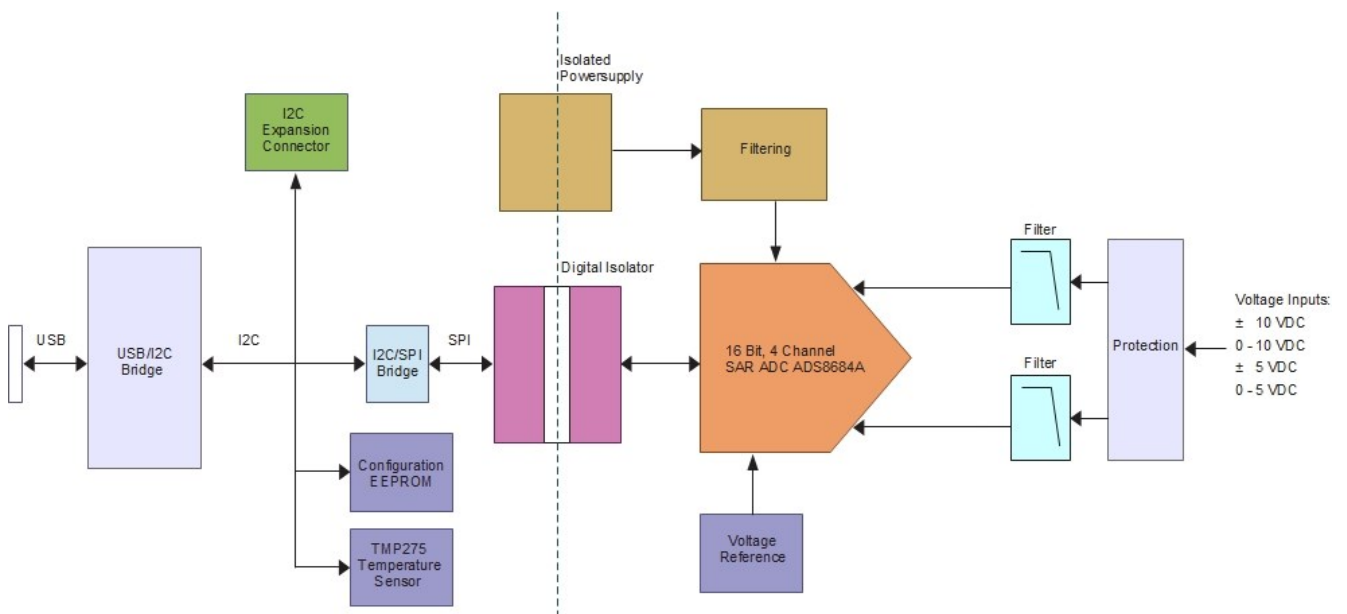

Fig. 1 Block Diagram

The main functional elements are:

- USB 2.0 local bus interface
- 4 isolated analog inputs with 16 bit resolution and programmable input range
- unipolar input ranges: 10.24V, 5.12V, 2.56V, 1.28V
- bipolar input ranges: $\pm 10.24V$, $\pm 5.12V$, $\pm 2.56V$, $\pm 1.28V_{dc}$, $\pm 0.64V$
- precision 4.096V reference
- onboard temperature sensor
- I2C expansion connector

The simplified input circuitry of a single AD channel is shown in Fig. 2.
The technical data of the board is listed in chapter 4.

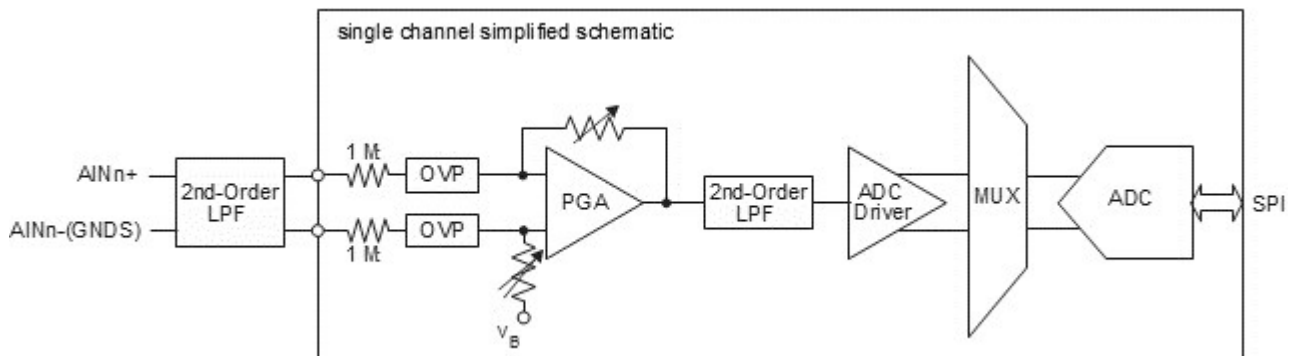

Fig. 2 Simplified Input Circuitry of a single AD Channel

Note that all input channel negativ inputs $AINn$ must use the same signal ground (GNDS). There is an internal connection on the board to prevent the negative inputs from drifting away.

2 Hardware Description

2.1. Overview

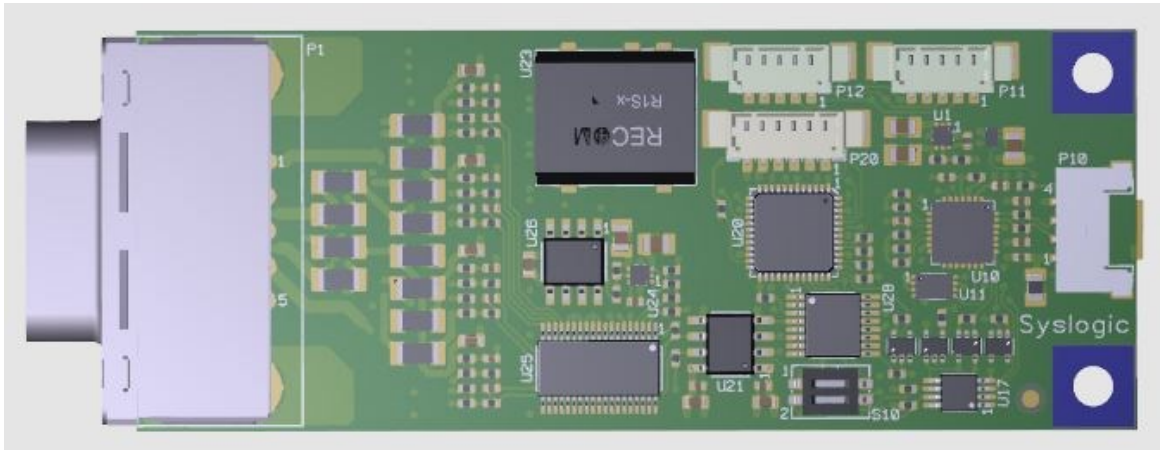

Fig. 3 Board Top View IPC/AI4VD-101E



Fig. 4 Board Top View IPC/AI4VT-101E

2.2. Addressing and Register Layout

Theoretical a maximum of four i/o boards can reside combined on the same physical I2C bus. Only one of them has to be connected to an USB or I2C host port (“Master”). The base configuration is done by setting switch S10 to the board address 0 to 3. This board address setting determines the final I2C address layout of the board.

Board Address	Device / Register	Remarks
S10 = 0x00		
0x50	USB Configuration EEPROM	“Master” only
0x51	Board Configuration EEPROM	type AT24C02
0x2C	Analog Input Port	type ADS8684A
0x4C	Temperature Sensor	type TMP275
S10 = 0x01		
0x50	USB Configuration EEPROM	“Master” only
0x53	Board Configuration EEPROM	type AT24C02
0x2D	Analog Input Port	type ADS8684A
0x4D	Temperature Sensor	type TMP275
S10 = 0x10		
0x50	USB Configuration EEPROM	“Master” only
0x55	Board Configuration EEPROM	type AT24C02
0x2E	Analog Input Port	type ADS8684A
0x4E	Temperature Sensor	type TMP275
S10 = 0x11		
0x50	USB Configuration EEPROM	“Master” only
0x57	Board Configuration EEPROM	type AT24C02
0x2F	Analog Input Port	type ADS8684A
0x4F	Temperature Sensor	type TMP275

Tab. 1 I/O Address Space Layout

Important Notes

Never configure multiple combined boards to the same S10 board address.
 Ensure that there is no I2C address overlapping between combined boards on the same I2C bus, otherwise the system may get damaged or may fail to operate.
 Only one of the combined boards may be connected to an USB or I2C host port.

2.3. Process Interface Connector Assignments

The input-/output connector pin assignment for the board is shown in Tab. 1 and 2. Please note that all inputs/outputs share a common external process signal ground and power supply. Signal sources (input signals) are connected between signal GNDS and the input pin of the IPC/AI4V.

Mating plug type IPC/ AI4VT-101E: Weidmüller B2CF 3.5/10/180F SN BK (Weidmüller ordering code 1277890000)

Field wiring solid or flexible H05 (07) V-U: AWG18...28 / 0.14-1.5 mm²

Field wiring with plastic collar ferrule, DIN 46228 pt 4: AWG18...28 / 0.14-1.0 mm²

I/O Connector Pin	Process Interface Signal	I/O Connector Pin	
1	Signal Ground (GNDS)	2	reserved
3	Input AIN0- (GNDS)	4	Input AIN0+
5	Input AIN1- (GNDS)	6	Input AIN1+
7	Input AIN2- (GNDS)	8	Input AIN2+
9	Input AIN3- (GNDS)	10	Input AIN3+

Tab. 2 Process Interface Connector P1 (IPC/ AI4VT-101E)

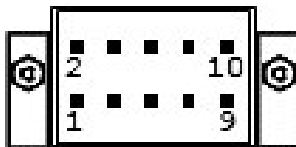

Fig. 5 Pinout IPC/AI4VT-101E (2x5 Pin Terminal Block, Front View)

I/O Connector Pin	Process Interface Signal	I/O Connector Pin	
1	Input AIN0+	6	Input AIN0- (GNDS)
2	Input AIN1+	7	Input AIN1- (GNDS)
3	Input AIN2+	8	Input AIN2- (GNDS)
4	Input AIN3+	9	Input AIN3- (GNDS)
5	Signal Ground (GNDS)		

Tab. 3 Process Interface Connector P1 (IPC/ AI4VD-101E)

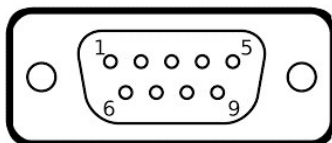

Fig. 6 Pinout IPC/AI4VD-101E (DSUB-9 male, Front View)

2.4. Local Bus Interface (USB)

The USB interface of the IPC/AI4V allows connection to a wide range of processor boards with a standard USB 2.0 interface. The bus connector pinout is shown in Tab. 3.

Mating plug type: Molex Pico-Lock 504051-0401 with AWG24 contacts 504052-0098

Cable type: Use AWG24 wire, USB Data – and Data+ wires should be twisted for proper operation

Pin Number	Signal	Remarks
1	Vusb	USB Supply Voltage 5V
2	D-	USB Data -
3	D+	USB Data +
4	GNDusb	USB Supply Ground

Tab. 4 USB Local Bus interface P10 (1x4 pin, male)

2.5. Local/Expansion Bus Interface (I2C)

The I2C interface of the IPC/AI4V allows connection to a wide range of processor boards with a 3.3V I2C interface. It also may be used to chain up to four modules to one USB- or I2C-host. The connector pinout is shown in Tab. 5.

Mating plug type: Molex Pico-Blade 51021-0500 with AWG26 contacts 50079-8100

Cable type: Use AWG26 wire

Pin Number	Signal	Remarks
1	Vcc	Supply Voltage 5V
2	SDA	I2C Data (3.3V CMOS level)
3	SCL	I2C Clock (3.3V CMOS level)
4	GND	Supply Ground
5	INT#	optional I2C interrupt line

Tab. 5 I2C Local/Expansion Bus interface P11 and P12 (1x5 pin, male)

Important Notes

Do not connect both, USB and I2C to a host. Leave USB connector P10 unconnected when using an I2C host.

Only one of the combined boards may be connected to an USB or I2C host port.

3 Programming Information

3.1. Overview

The programming of the AI4V board is done with USB read and write operations. For Windows and Linux operating systems an application programming library and sample code is available.

Check the library and sample code to see how the different I2C devices have to be set up for proper operation.

Do not modify the contents of the USB and board configuration EEPROMs otherwise you risk that the board does not work anymore and must be returned to factory.

The AD converter is connected through a transparent I2C-to-SPI bridge to the internal I2C bus. The detailed programming information for the AD converter may be found in the latest datasheet of the Texas Instruments ADS8684A device.

For improved performance, all “Manual Channel n Select” (MAN-Ch_n) commands sent to the ADS8684A are extended by the I2C-to-SPI bridge by automatically adding a “Continued Operation” (NO_OP) command in the same I2C transfer cycle so the next read immediately returns the conversion result of the actual requested channel instead of the previously selected channel, saving an additional I2C write sequence.

The ALARM output of the ADS8684A is not connected in this design, so alarm processing can only be done by polling the alarm flags, not by hardware interrupts.

<http://www.ti.com/lit/gpn/ads8684a>

The temperature sensor chip TMP275 is soldered on the board. Therefore the measured temperature is more a chip or pcb board temperature than an ambient temperature and it is dependent on the mounting direction of the whole system. This must be taken into account when using this sensor for temperature measurement. The detailed programming information may be found in the latest datasheet of the Texas Instruments TMP275 device.

<http://www.ti.com/lit/gpn/tmp275>

4 Technical Data

4.1. Electrical Data

Important Note

Do not operate the AI4V board outside of the recommended operating conditions. Otherwise lifetime and performance will degrade.
Operating the board outside of the absolute maximum ratings may damage the hardware.

Absolute Maximum Ratings (over free-air temperature range)

Parameter	Symbol	Min	Typ	Max	Unit
USB supply voltage	Vcc	-0.5		5.5	Vdc
process input voltage between inputs AIN0+..3+ and GNDS	Vin	-12		+12	Vdc
isolation: process to chassis (AC, 60s, 500m a.s.l., Ta=25°C)		1000			Vrms
process to logic (AC, 60s, 500m a.s.l., Ta=25°C)		1000			Vrms
creepage distance: logic to chassis		2.0			mm
creepage distance: process to chassis		2.0			mm
process to logic (excluding chassis path)		2.5			mm

Tab. 6 Absolute Maximum Ratings

Recommended Operating Conditions

parameter	Symbol	min	nom	max	Unit
USB supply voltage	Vcc(usb)	4.75	5.00	5.25	V
I2C supply voltage (not data signal voltage!)	Vcc(i2c)	4.75	5.00	5.25	V
input voltage at AIN0+..3+ referenced to GNDS	Vin+				V
input range +/-2.5xVref		-10.24		10.24	
input range +/-1.25xVref		-5.12		5.12	
input range +/-0.625xVref		-2.56		2.56	
input range +/-0.3125xVref		-1.28		1.28	
input range +/-0.15625xVref		-0.64		0.64	
input range 2.5xVref		0		10.24	
input range 1.25xVref		0		5.12	
input range 0.625xVref		0		2.56	
input range 0.3125xVref		0		1.28	
input voltage at AIN0-..3- referenced to GNDS	Vin-	-0.1		0.1	V
operating free-air ambient temperature range	Ta	-40		+85	°C

Tab. 7 Recommended Operating Conditions

Electrical Characteristics

(over recommended operating range, unless otherwise noted)

parameter	Symbol	min	typ	max	Unit
USB supply current (Vcc=5.0V)	Icc			tbd	mA
AD converter reference voltage (25°C)	Vref	4.095	4.096	4.097	V
AD converter reference voltage temperature drift			2	tbd	ppm
input impedance at AIN0+..3+	Rin	0.85		1.15	MΩ
input current at AIN0+..3+ (Vin=-10.24..+10.24V)	Iin+	-15		10	uA
input current at AIN0+..3+ (Vin=-5.12..+5.12V)	Iin+	-10		4	uA
AD conversion resolution			16		bit
AD conversion accuracy note: due to an additional low pass filter with 430 Ω resistance, the input current through this filter adds a small voltage drop			see TI ADS8684A datasheet		

Tab. 8 Electrical Characteristics

Switching Characteristics (nominal conditions)

parameter	Symbol	min	typ	max	Unit
conversion frequency (all channels, sequential)	fimax			tbd	Hz

Tab. 9 Switching Characteristics

4.2. Mechanical Data

The AI4V board is available in two functionally identical variants, IPC/AI4VD-101E and IPC/AI4VT-101E. They only differ in the connector type, DSUB-9 for AI4VD, terminal block for AI4VT (see technical data section).

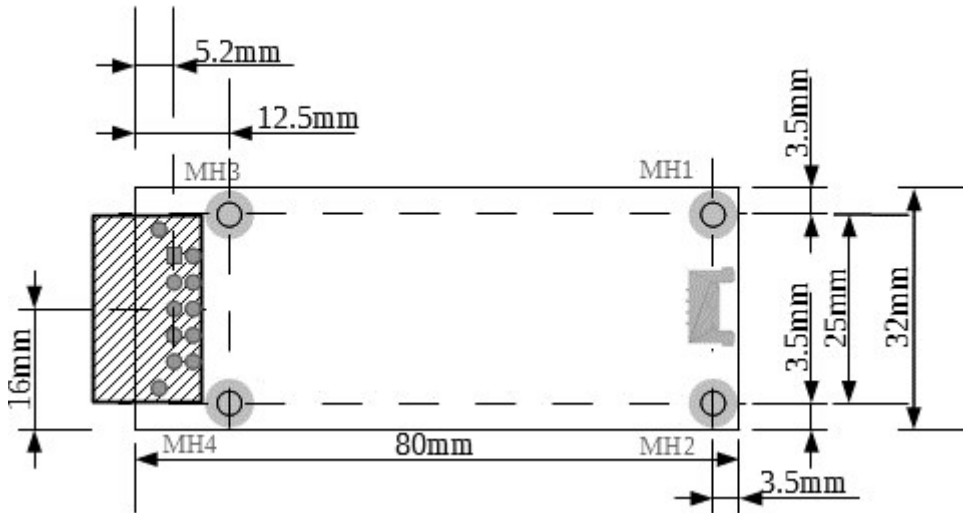

Fig. 7 Mechanical Dimensions IPC/AI4VT-101E (2x5 Pin Terminal Block)

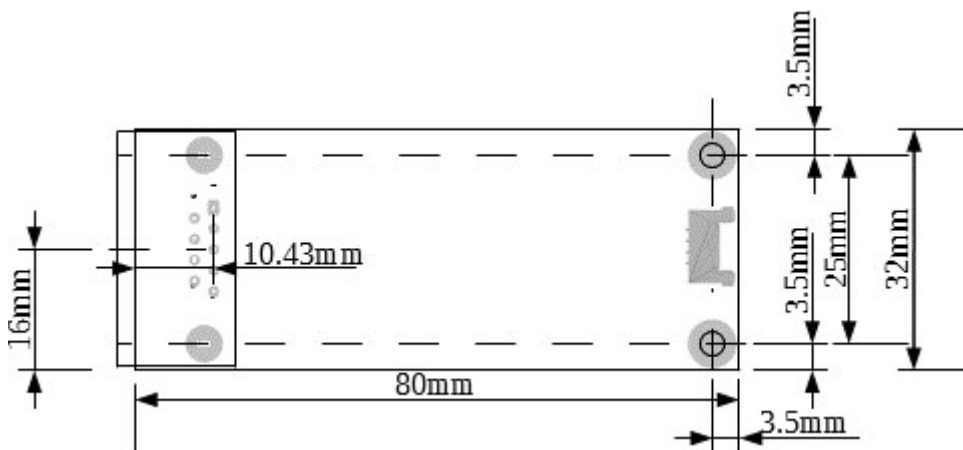

Fig. 8 Mechanical Dimensions IPC/AI4VD-101E (9 Pin DSUB)