



**Commercial Grade
-250SH series
SSD**

Product Manual

January 3, 2018

www.cactus-tech.com

The information in this manual is preliminary and is subject to change without notice. Cactus Technologies[®], Limited shall not be liable for technical or editorial errors or omissions contained herein; nor for incidental or consequential damages resulting from the furnishing, performance, or use of this material.

Cactus Technologies[®] makes no warranty, representation or guarantee regarding the suitability of its products for any particular purpose, nor does Cactus Technologies[®] assume any liability arising out of the application or use of its products, and specifically disclaims any and all liability, including without limitation consequential or incidental damages.

Cactus Technologies[®] products are not designed, intended or authorized for use as components in systems intended for surgical implant into the body or in other applications intended to support or sustain life or for any application where the failure of a Cactus Technologies[®] product can result in personal injury or death. Users of Cactus Technologies[®] products for such unintended and unauthorized applications shall assume all risk of such use and shall indemnify and hold Cactus Technologies[®] and its officers, employees, subsidiaries, affiliates and distributors harmless against all claims, costs, damages, expenses and attorney fees arising out of, directly or indirectly, any claim of personal injury or death associated with such unintended and unauthorized use, even if such claim alleges that Cactus Technologies[®] was negligent regarding the design or manufacture of the part.

All parts of the Cactus Technologies[®] documentation are protected by copyright law and all rights are reserved. This documentation may not, in whole or in part, be copied, photocopied, reproduced, translated, or reduced to any electronic medium or machine-readable form without prior consent, in writing, from Cactus Technologies[®], Limited.

© 2005-2018 Cactus Technologies[®] Limited. All rights reserved.

Table of Contents

1.Introduction to Cactus Technologies® Commercial Grade -250SH Series SSD Products.....	5
1.1.Supported Standards.....	6
1.2.Product Features.....	6
1.2.1.Host and Technology Independence.....	6
1.2.2.Defect and Error Management.....	6
1.2.3.Power Supply Requirements.....	7
2.Product Specifications.....	7
2.1.System Environmental Specifications.....	7
2.2.System Power Requirements.....	7
2.3.System Performance.....	8
2.4.System Reliability.....	8
2.5.Physical Specifications.....	8
2.6.Capacities.....	10
3.Interface Description.....	11
3.1.SSD Pin Assignments and Pin Type.....	11
3.2.Electrical Specifications.....	11
3.2.1.Absolute Maximum Ratings.....	12
3.2.2.DC Characteristics.....	12
3.2.3.AC Characteristics.....	12
4.ATA Drive Register Set Definition and Protocol.....	12
4.1.ATA Task File Definitions.....	12
4.1.1.Data Register.....	13
4.1.2.Error Register.....	13
4.1.3.Feature Register.....	13
4.1.4.Sector Count Register.....	13
4.1.5.Sector Number (LBA 7-0) Register.....	13
4.1.6.Cylinder Low (LBA 15-8) Register.....	13
4.1.7.Cylinder High (LBA 23-16) Register.....	14
4.1.8.Drive/Head (LBA 27-24) Register.....	14
4.1.9.Status Registers.....	14
4.1.10.Device Control Register.....	15
4.1.11.Drive Address Register.....	15
5.ATA Command Description.....	16
5.1.ATA Command Set.....	16
5.1.1.Identify Drive—ECH.....	18
6. S.M.A.R.T. Feature Set.....	20
6.1.S.M.A.R.T Data Structure.....	20
6.2.S.M.A.R.T Attribute Data Structure.....	21
6.3.S.M.A.R.T Attributes.....	21
6.4.S.M.A.R.T Execute Off-line Immediate (subcommand D4h).....	23
6.5.S.M.A.R.T Read Log (subcommand D5h).....	24
6.5.1.S.M.A.R.T Log Directory Structure.....	24
6.5.2.Self-test Log Structure.....	24
6.5.3.SelectiveSelf-test Log Structure.....	25

6.6.S.M.A.R.T Write Log Sector (subcommand D6h).....26
6.7.S.M.A.R.T Enable Operations (subcommand D8h).....26
6.8.S.M.A.R.T Disable Operations (subcommand D9h).....26
6.9.S.M.A.R.T Return Status (subcommand DAh).....26

Appendix A. Ordering Information.....27

Appendix B. Technical Support Services.....28

Appendix C. Cactus Technologies® Worldwide Sales Offices.....29

Appendix D. Limited Warranty.....30

1. Introduction to Cactus Technologies® Commercial Grade -250SH Series SSD Products

Features:

- Solid state design with no moving parts
- Available in industry standard 2.5" 7mm or 9.5mm height form factor
- Capacities: 2TB, 4TB, 8TB
- Compliant with Serial ATA 3.0 specifications
- ATA8-ACS2 command set compatible
- Supports Serial ATA Generation I/II/III transfer rate of 1.5/3.0/6.0Gbps
- Supports ATA SMART Feature Set
- Supports ATA Security Feature Set
- Supports Data Set Management Trim command
- Supports SATA NCQ with max. Queue depth of 32
- ECC capable of correcting up to 64 bit errors per 1KB
- Enhanced error correction, < 1 error in 10¹⁵ bits read
- SATA partial and slumber modes supported
- Optional jumper triggered Write Protect or Secure Erase
- Voltage support: 5.0V±10%

Cactus Technologies® -250SH series SSD is a high capacity solid-state flash memory product that complies with the Serial ATA 3.0 standard and is functionally compatible with a SATA hard disk drive. Cactus Technologies® -250SH series SSD provide up to 8TB of formatted storage capacity.

Cactus Technologies® -250SH series SSD product uses high quality MLC HLNAND flash memory from Hynix Corporation. In addition, it includes an on-drive intelligent controller that manages interface protocols, data storage and retrieval as well as ECC, defect handling and diagnostics, power management, and clock control. The controller's firmware is upgradeable, thus allowing feature enhancements and firmware updates while keeping the BOM stable.

1.1. Supported Standards

Cactus Technologies® -250SH series SSD is fully compatible with the following specification:

- ATA 8 Specification published by ANSI
- Serial ATA 3.0 Specification published by the Serial ATA International Organization

1.2. Product Features

Cactus Technologies® Commercial SSD contains a high level, intelligent controller. This intelligent controller provides many capabilities including the following:

- Standard ATA register and command set (same as found on most magnetic disk drives).
- Manages details of erasing and programming flash memory independent of the host system
- Sophisticated defect managing capabilities (similar to magnetic disk drives).
- Sophisticated system for error recovery using powerful error correction code (ECC).
- Intelligent power management for low power operation.

1.2.1. Host and Technology Independence

Cactus Technologies® Commercial SSD appears as a standard SATA disk drive to the host system. The drive utilizes a 512-byte sector which is the same as that in an IDE magnetic disk drive. To write or read a sector (or multiple sectors), the host computer software simply issues an ATA Read or Write command to the drive as per the SATA protocol. The host software then waits for the command to complete. The host system does not get involved in the details of how the flash memory is erased, programmed or read as this is all managed by the built-in controller in the drive. Also, with the intelligent on-board controller, the host system software will not require changing as new flash memory evolves. Thus, systems that support the Cactus Technologies® Commercial SSD products today will continue to work with future Cactus Technologies® Commercial SSDs built with new flash technology without having to update or change host software.

1.2.2. Defect and Error Management

Cactus Technologies® Commercial SSD contains a sophisticated defect and error management system similar to those found in magnetic disk drives. The defect management is completely transparent to the host and does not consume any user data space.

The soft error rate for Cactus Technologies® Commercial SSD is much lower than that of magnetic disk drives. In the extremely rare case where a read error does occur, the drive has sophisticated ECC to recover the data.

These defect and error management systems, coupled with the solid-state construction, give Cactus Technologies® Commercial SSDs unparalleled reliability.

1.2.3. Power Supply Requirements

Cactus Technologies® Commercial SSD operates at a voltage range of 5.0 volts ± 10%.

2. Product Specifications

For all the following specifications, values are defined at ambient temperature and nominal supply voltage unless otherwise stated.

2.1. System Environmental Specifications

Table 2-1. Environmental Specifications

		Cactus Technologies® -250SH SSD
Temperature	Operating:	0° C to +70° C (Standard) -40° C to +85° C (extended)
Humidity	Operating & Non-Operating:	8% to 95%, non-condensing
Vibration	Operating & Non-Operating:	20G, MIL-STD-883G Method 2005.2, Condition A
Shock	Operating & Non-Operating:	3,000 G, MIL-STD-883G Method 2002.4, Condition C
Altitude (relative to sea level)	Operating & Non-Operating:	100,000 feet maximum

2.2. System Power Requirements

Table 2-2. Power Requirements

		Cactus Technologies® -250SH SSD		
DC Input Voltage (VCC) 100 mV max. ripple (p-p)		5.0V ±10%		
(Maximum Average Value) See Notes.	Standby:	2TB 415mA	4TB 440mA	8TB 585mA
	Reading:	615mA	670mA	830mA
	Writing:	1100mA	1160mA	1250mA

NOTES: All values quoted are typical at ambient temperature and nominal supply voltage unless otherwise stated.

Sleep mode is specified under the condition that all drive inputs are static CMOS levels and in a “Not Busy” operating state.

2.3. System Performance

All performance timings assume the drive controller is in the default (i.e., fastest) mode.

Table 2-3. Performance

		2TB	4TB	8TB
Read Transfer Rate	Sequential	Up to 485MB/sec	Up to 415MB/s	Up to 420MB/s
Write Transfer Rate	Sequential	Up to 425MB/sec	Up to 415MB/s	Up to 415MB/s
IOPS	4K random read	Up to 49K	Up to 37K	Up to 43K
	4K random write	Up to 45K	Up to 42K	Up to 41K

2.4. System Reliability

Table 2-4. Reliability

Data Reliability	< 1 non-recoverable error in 10^{15} bits READ
Endurance (estimated TBW):	2TB: Up to 500TB 4TB: Up to 1000TB 8TB: Up to 2000TB

2.5. Physical Specifications

The following sections provide the physical specifications for Cactus Technologies® Commercial SSD products.

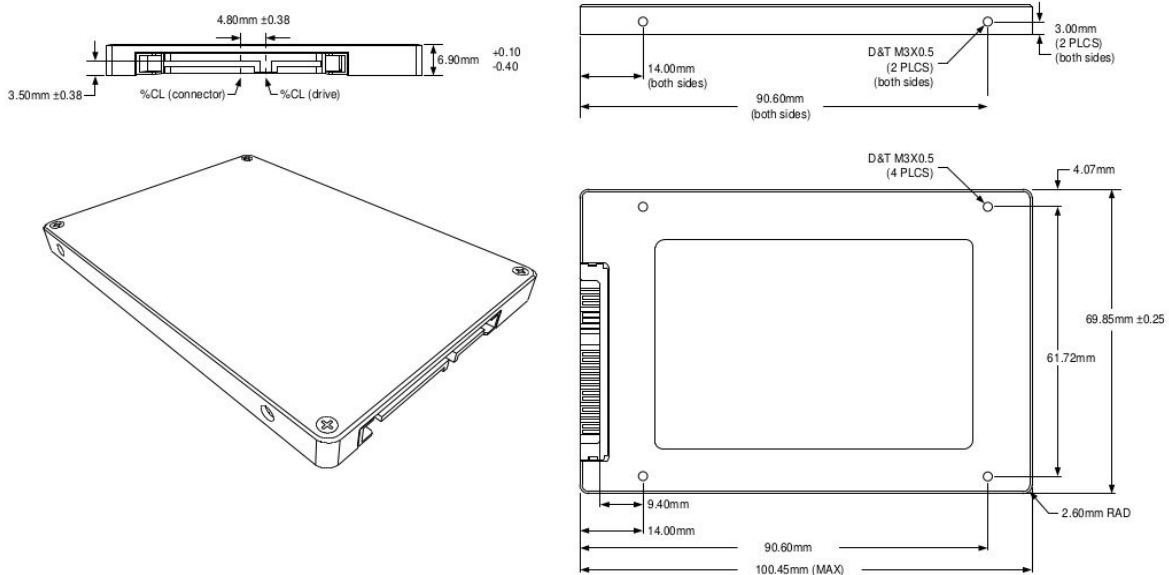

Figure 2-1. 250SH 2.5'' SSD Dimensions (7mm, 2TB)

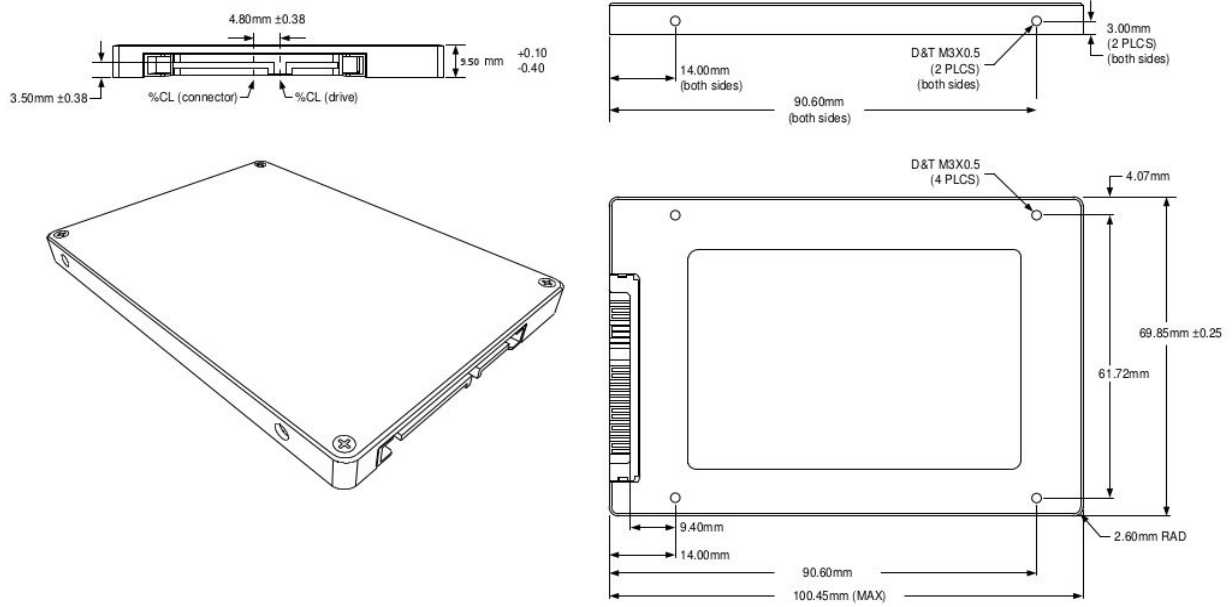

Figure 2-2. 250SH 2.5" SSD Dimensions (9.5mm, 4TB & 8TB std. Temp.)

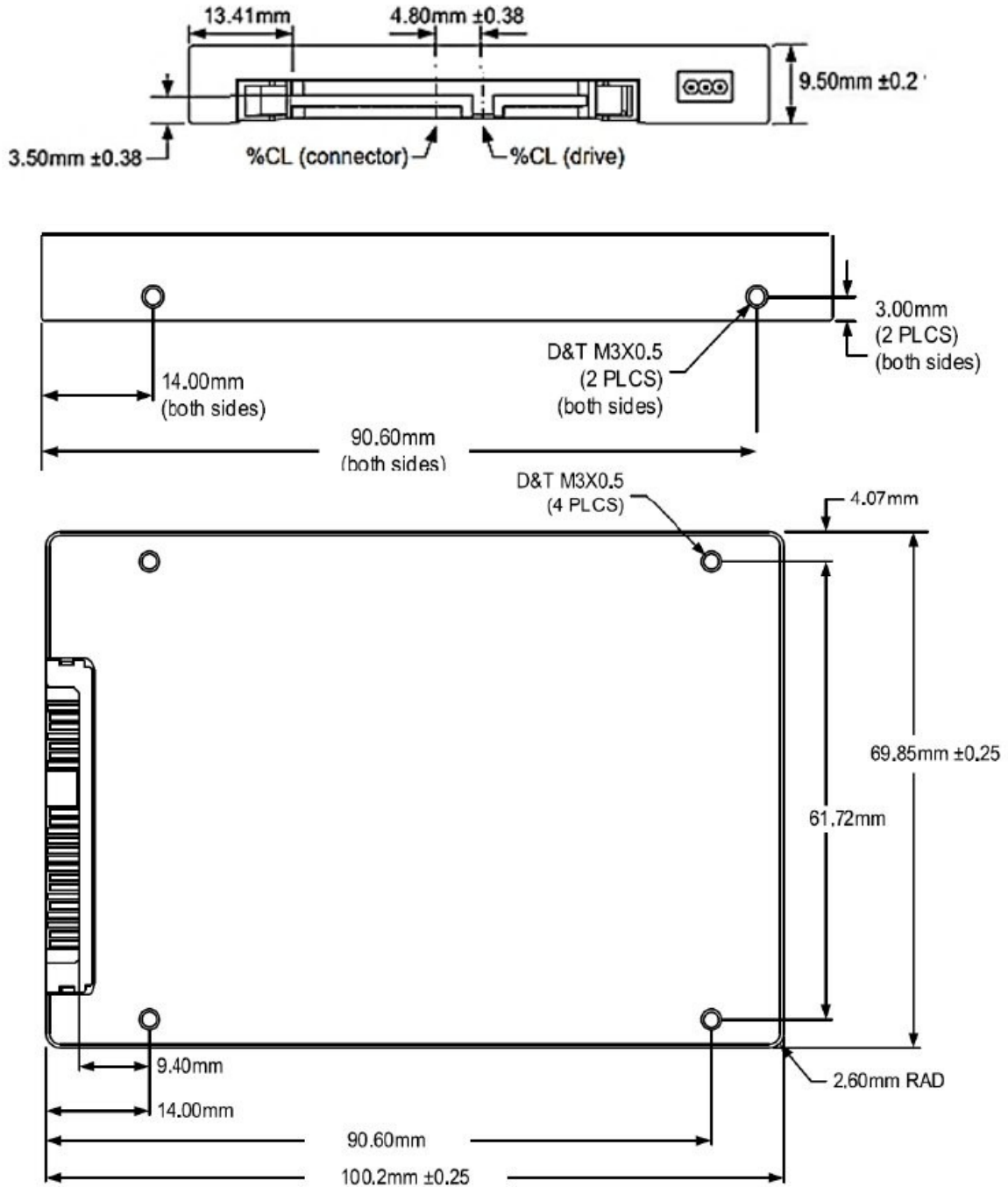

Figure 2-3. 250SH 2.5" SSD w/ jumper option Dimensions (9.5mm, 4TB & 8TB ext. temp.)

2.6. Capacities

The following table lists the available parts in the Cactus Technologies® -250SH series SSDs:

Standard Temp.			Extended Temp.		
2TB	4TB	8TB	2TB	4TB	

3. Interface Description

The following sections provide detailed information on the Cactus Technologies® Commercial SSD interface.

3.1. SSD Pin Assignments and Pin Type

Cactus Technologies® SSD uses industry standard 7+12 SATA connector. The signal/pin assignments and descriptions are listed in Table 3-5.

Table 3-5. SSD Pin Assignments and Pin Type

Signal Segment Pin #	Signal Name	Pin Type	Power Segment Pin #	Signal Name	Pin Type
S1	GND		P1	3.3V	
S2	RXP	Analog In	P2	3.3V	
S3	RXN	Analog In	P3	3.3V	
S4	GND		P4	GND	
S5	TXN	Analog Out	P5	GND	
S6	TXP	Analog Out	P6	GND	
S7	GND		P7	5V	
			P8	5V	
			P9	5V	
			P10	GND	
			P11	Active LED	
			P12	GND	
			P13	12V	
			P14	12V	
			P15	12V	

3.2. Electrical Specifications

The following table defines all D.C. Characteristics for the SSD products. Unless otherwise stated, conditions are:

$$V_{cc} = 5.0V \pm 10\%$$

$$T_a = -40^{\circ}C \text{ to } 85^{\circ}C$$

3.2.1. Absolute Maximum Ratings

Parameter	Symbol	MIN	MAX	Units
Storage Temperature	T _S	-55	+100	°C
Operating Temperature	T _A	-40	+85	°C
Vcc with respect to GND	Vcc	-0.3	5.5	V

3.2.2. DC Characteristics

Parameter	Symbol	MIN	MAX	Units
Input Voltage	V _{in}	-0.5	Vcc + 0.5	V
Output Voltage	V _{out}	-0.3	Vcc + 0.3	V
Input Leakage Current	I _{LI}	-10	10	uA
Output Leakage Current	I _{LO}	-10	10	uA
Input/Output Capacitance	C _I /C _O		10	pF
Power Consumption (max):	P _{max}			mA
Idle			590	
Active			1260	

3.2.3. AC Characteristics

Cactus Technologies® Commercial SSD products conforms to all AC timing requirements as specified in the SATA-IO specifications. Please refer to that document for details of AC timing for all operation modes of the device.

4.ATA Drive Register Set Definition and Protocol

The communication to or from the SSD is done using FIS. Legacy ATA protocol is supported by using the legacy mode defined in the SATA specifications. In this mode, the FIS has defined fields which provide all the necessary ATA task file registers for control and status information. The Serial ATA interface does not support Primary/Secondary or Master/Slave configurations. Each SATA channel supports only one SATA device, with the register selection as defined by the ATA standard.

4.1. ATA Task File Definitions

The following sections describes the usage of the ATA task file registers. Note that the Alternate Status Register of legacy ATA is not defined for SATA drives.

4.1.1. Data Register

The Data Register is a 16-bit register, and it is used to transfer data blocks between the SSD data buffer and the Host.

4.1.2. Error Register

This register contains additional information about the source of an error when an error is indicated in bit 0 of the Status register. The bits are defined as follows:

D7	D6	D5	D4	D3	D2	D1	D0
BBK	UNC	0	IDNF	0	ABRT	0	AMNF

- Bit 7 (BBK)** This bit is set when a Bad Block is detected.
- Bit 6 (UNC)** This bit is set when an Uncorrectable Error is encountered.
- Bit 5** This bit is 0.
- Bit 4 (IDNF)** The requested sector ID is in error or cannot be found.
- Bit 3** This bit is 0.
- Bit 2 (Abort)** This bit is set if the command has been aborted because of a status condition: (Not Ready, Write Fault, etc.) or when an invalid command has been issued.
- Bit 1** This bit is 0.
- Bit 0 (AMNF)** This bit is set in case of a general error.

4.1.3. Feature Register

This register provides information regarding features of the SSD that the host can utilize.

4.1.4. Sector Count Register

This register contains the number of sectors of data requested to be transferred on a read or write operation between the host and the SSD. If the value in this register is zero, a count of 256 sectors is specified. If the command was successful, this register is zero at command completion. If not successfully completed, the register contains the number of sectors that need to be transferred in order to complete the request.

4.1.5. Sector Number (LBA 7-0) Register

This register contains the starting sector number or bits 7-0 of the Logical Block Address (LBA) for any SSD data access for the subsequent command.

4.1.6. Cylinder Low (LBA 15-8) Register

This register contains the low order 8 bits of the starting cylinder address or bits 15-8 of the Logical Block Address.

4.1.7. Cylinder High (LBA 23-16) Register

This register contains the high order bits of the starting cylinder address or bits 23-16 of the Logical Block Address.

4.1.8. Drive/Head (LBA 27-24) Register

The Drive/Head register is used to select the drive and head. It is also used to select LBA addressing instead of cylinder/head/sector addressing. The bits are defined as follows:

D7	D6	D5	D4	D3	D2	D1	D0
1	LBA	1	DRV	HS3	HS2	HS1	HS0

Bit 7 This bit is set to 1.

Bit 6 LBA is a flag to select either Cylinder/Head/Sector (CHS) or Logical Block Address Mode (LBA). When LBA=0, Cylinder/Head/Sector mode is selected. When LBA=1, Logical Block Address is selected. In Logical Block Mode, the Logical Block Address is interpreted as follows:
 LBA07-LBA00: Sector Number Register D7-D0.
 LBA15-LBA08: Cylinder Low Register D7-D0.
 LBA23-LBA16: Cylinder High Register D7-D0.
 LBA27-LBA24: Drive/Head Register bits HS3-HS0.

Bit 5 This bit is set to 1.

Bit 4 (DRV) DRV is the drive number. This should always be set to 0.

Bit 3 (HS3) When operating in the Cylinder, Head, Sector mode, this is bit 3 of the head number. It is Bit 27 in the Logical Block Address mode.

Bit 2 (HS2) When operating in the Cylinder, Head, Sector mode, this is bit 2 of the head number. It is Bit 26 in the Logical Block Address mode.

Bit 1 (HS1) When operating in the Cylinder, Head, Sector mode, this is bit 1 of the head number. It is Bit 25 in the Logical Block Address mode.

Bit 0 (HS0) When operating in the Cylinder, Head, Sector mode, this is bit 0 of the head number. It is Bit 24 in the Logical Block Address mode.

4.1.9. Status Registers

These registers return the status when read by the host. Reading the Status register does clear a pending interrupt while reading the Auxiliary Status register does not. The meaning of the status bits are described as follows:

D7	D6	D5	D4	D3	D2	D1	D0
BUSY	RDY	DWF	DSC	DRQ	CORR	0	ERR

- Bit 7 (BUSY)** The busy bit is set when the device has access to the command buffer and registers and the host is locked out from accessing the command register and buffer. No other bits in this register are valid when this bit is set to a 1.
- Bit 6 (RDY)** RDY indicates whether the device is capable of performing operations requested by the host. This bit is cleared at power up and remains cleared until the device is ready to accept a command.
- Bit 5 (DWF)** This bit, if set, indicates a write fault has occurred.
- Bit 4 (DSC)** This bit is set when the device is ready.
- Bit 3 (DRQ)** The Data Request is set when the device requires that information be transferred either to or from the host through the Data register.
- Bit 2 (CORR)** This bit is set when a Correctable data error has been encountered and the data has been corrected. This condition does not terminate a multi-sector read operation.
- Bit 1 (IDX)** This bit is always set to 0.
- Bit 0 (ERR)** This bit is set when the previous command has ended in some type of error. The bits in the Error register contain additional information describing the error.

4.1.10. Device Control Register

This register is used to control the drive interrupt request and to issue an ATA soft reset to the drive. The bits are defined as follows:

D7	D6	D5	D4	D3	D2	D1	D0
HOB	X	X	X	1	SW Rst	-IEEn	0

- Bit 7** This bit is used in 48-bit addressing mode. When cleared, the host can read the most recently written values of the Sector Count, Drive/Head and LBA registers. When set, the host will read the previous written values of these registers. A write to any Command block register will clear this bit.
- Bit 6** This bit is an X (Do not care).
- Bit 5** This bit is an X (Do not care).
- Bit 4** This bit is an X (Do not care).
- Bit 3** This bit is ignored by the drive.
- Bit 2 (SW Rst)** This bit is set to 1 in order to force the drive to perform an AT Disk controller Soft Reset operation. The drive remains in Reset until this bit is reset to '0'.
- Bit 1 (-IEEn)** The Interrupt Enable bit enables interrupts when the bit is 0. When the bit is 1, interrupts from the drive are disabled. This bit is set to 0 at power on and Reset.
- Bit 0** This bit is ignored by the drive.

4.1.11. Drive Address Register

This register is provided for compatibility with the AT disk drive interface. It is recommended that this register not be mapped into the host's I/O space because of potential conflicts on Bit 7. The bits are defined as follows:

D7	D6	D5	D4	D3	D2	D1	D0
X	-WTG	-HS3	-HS2	-HS1	-HS0	-nDS1	-nDS0

- Bit 7** This bit is unknown.
Implementation Note:
Conflicts may occur on the host data bus when this bit is provided by a Floppy Disk Controller operating at the same addresses as the SSD. Following are some possible solutions to this problem:

1. Locate the SSD at a non-conflicting address (i.e., Secondary address (377) when a Floppy Disk Controller is located at the Primary addresses).
2. Do not install a Floppy and a SSD in the system at the same time.
3. Implement a socket adapter that can be programmed to (conditionally) tri-state D7 of I/O address 3F7/377 when a SSD product is installed and conversely to tri-state D6-D0 of I/O address 3F7/377 when a floppy controller is installed.
4. Do not use the SSD's Drive Address register. This may be accomplished by either a) If possible, program the host adapter to enable only I/O addresses 1F0-1F7, 3F6 (or 170-177, 176) to the SSD or b) if provided use an additional Primary/Secondary configuration in the SSD that does not respond to accesses to I/O locations 3F7 and 377. With either of these implementations, the host software must not attempt to use information in the Drive Address Register.

Bit 6 (-WTG) This bit is 0 when a write operation is in progress, otherwise, it is 1.

Bit 5 (-HS3) This bit is the negation of bit 3 in the Drive/Head register.

Bit 4 (-HS2) This bit is the negation of bit 2 in the Drive/Head register.

Bit 3 (-HS1) This bit is the negation of bit 1 in the Drive/Head register.

Bit 2 (-HS0) This bit is the negation of bit 0 in the Drive/Head register.

Bit 1 (-nDS1) This bit is 0 when drive 1 is active and selected.

Bit 0 (-nDS0) This bit is 0 when the drive 0 is active and selected.

5. ATA Command Description

This section defines the ATA command set supported by Cactus Technologies® -250SH series SSDs.

5.1. ATA Command Set

Table 5-6 summarizes the supported ATA command set .

Table 5-6. ATA Command Set

COMMAND	Code
Check Power Mode	E5h, 98h
Device Reset	08h
Device Configuration	-
Device Configuration Freeze Lock	B1h/C1h
Device Configuration Identify	B1h/C2h
Device Configuration Restore	B1h/C0h
Device Configuration Set	B1h/C3h
Download Microcode	92h
Data Set Management	06h
Execute Drive Diagnostic	90h
Flush Cache	E7h
Flush Cache Ext	EAh
Identify Drive	ECh
Idle	E3h, 97h
Idle Immediate	E1h, 95h
Initialize Drive Parameters	91h
Read Buffer	E4h
Read DMA	C8h
Read DMA Ext	25h
Read FDPMA Queued	60h
Read Log Ext	2Fh
Read Multiple	C4h

COMMAND	Code
Read Multiple Ext	29h
Read Native Max Address	F8h
Read Native Max Address Ext	27h
Read Sector(s)	20h
Read Sector(s) Ext	24h
Read Verify Sector(s)	40h
Read Verify Sector(s) Ext	42h
Security Disable Password	F6h
Security Erase Prepare	F3h
Security Erase Unit	F4h
Security Freeze Lock	F5h
Security Set Password	F1h
Security Unlock	F2h
Seek	70h
Set Features *	EFh
Enable Write Cache	Efh/02h
Disable Write Cache	EFh/82h
Set Transfer Mode	EFh/03h
Enable Power-up In Standby	EFh/06h
Disable Power-up In Standby	EFh/08h
Enable DMA Setup FIS Auto-Activate optimization	EFh/10h/02h
Disable DMA Setup FIS Auto-Activate optimization	EFh/90h/02h
Enable Device-initiated interface power state transitions	EFh/10h/03h
Disable Device-initiated interface power state transitions	EFh/90h/03h
Set Max	
Set Max Address	F9h
Set Max Freeze Lock	F9h/04h
Set Max Lock	F9h/02h
Set Max Set Password	F9h/01h
Set Max Unlock	F9h/03h
Set Max Address Ext	37h
Set Multiple Mode	C6h
Set Sleep Mode	E6h, 99h
SMART	
SMART Disable Operations	B0h/D9h
SMART Enable Operations	B0h/D8h
SMART Enable/Disable Attribute Autosave	B0h/D2h
SMART Execute Off-line Immediate	B0h/D4h
SMART Read Attribute Thresholds	B0h/D1h
SMART Read Data	B0h/D0h
SMART Read Log	B0h/D5h
SMART Return Status	B0h/DAh
SMART Save Attribute Values	B0h/D3h
SMART Write Log	B0h/D6h
Stand By	E2h, 96h
Stand By Immediate	E0h, 94h
Soft Reset	FFh
Write Buffer	E8h
Write DMA	CAh

COMMAND	Code
Write DMA Ext	35h
Write FPDMA Queued	61h
Write Log Ext	3Fh
Write Multiple	C5h
Write Multiple Ext	39h
Write Sector(s)	30h
Write Sector(s) Ext	34h

5.1.1. Identify Drive—ECH

The Identify Drive command enables the host to receive parameter information from the drive. This command has the same protocol as the Read Sector(s) command. The parameter words in the buffer have the arrangement and meanings defined in Table 5-7. All reserved bits or words are zero. Table 5-7 is the definition for each field in the Identify Drive Information.

Table 5-7. Identify Drive Information

Word Address	Default Value	Total Bytes	Data Field Type Information
0	0040H	2	General configuration bit-significant information.
1	3FFFH	2	Default number of cylinders; capacity dependent.
2	C837H	2	Reserved
3	0010H	2	Default number of heads; capacity dependent.
4-5	0H	4	Retired
6	003FH	2	Default number of sectors per track; capacity dependent.
7-8	0h	4	Reserved
9	0H	2	Retired
10-19	aaaa	20	Serial number in ASCII (Right Justified).
20-21	0H	4	Retired
22	0H	2	Obsolete
23-26	aaaa	8	Firmware revision in ASCII . Big Endian Byte Order in Word.
27-46	aaaa	40	Model number in ASCII (Left Justified) Big Endian Byte Order in Word.
47	8001H	2	Maximum number of sectors on Read/Write Multiple command: 2
48	4000H	2	Trusted Computing Feature Set
49	2F00H	2	Capabilities: DMA, LBA, IORDY supported
50	4000H	2	Capabilities: device specific standby timer minimum
51	0H	2	Obsolete
52	0H	2	Obsolete
53	0007H	2	Words 88 and 70:64 valid
54	3FFFH	2	Obsolete
55	0010H	2	Obsolete
56	003FH	2	Obsolete
57-58	0H	4	Obsolete
59	0101H	2	Number of sectors transferred per interrupt
60-62	XXXX	6	Total number of sectors addressable
63	0007H	2	Multiword DMA modes 0-2 are supported; upper byte reflects currently selected MWDMA mode.
64	0003H	2	Advanced PIO modes supported (modes 3 and 4)
65	0078H	2	Minimum MWDMA cycle time per word is 120ns.
66	0078H	2	Recommended MWDMA cycle time is 120ns.
67	0078H	2	Minimum PIO cycle time without IORDY flow control is 120ns.
68	0078H	2	Minimum PIO cycle time with IORDY flow control is 120ns.

Word Address	Default Value	Total Bytes	Data Field Type Information
69	0H	2	Additional features supported
70	0H	2	Reserved
71-74	0H	8	Reserved
75	001FH	2	Queue depth of 32 for NCQ
76	850EH	2	SATA capabilities
77	0006H	6	Reserved
78	0040H	2	Support of SerialATA functions
79	0040H	2	Serial ATA functions enabled
80	01E0H	2	Major revision number
81	0000H	2	Minor revision number
82	346BH	2	Command set supported
83	7D01H	2	Command set supported
84	4122H	2	Command set/feature supported extension
85	3469H	2	Command set/feature enabled
86	3C01H	2	Command set/feature enabled
87	4122H	2	Command set/feature default
88	007FH	2	UDMA Modes 0-6 supported.
89	0001H	2	Time required for security erase unit completion
90	006EH	2	Time required for enhanced security erase unit completion
91	0000H	2	Current advanced power management value
92	FFFEH	2	Master password revision code
93	0H	2	Hardware reset default
94	0H	2	Vendor's recommended acoustic management value
95	0H	2	Stream minimum request size
96	0H	2	Streaming transfer time - DMA
97	0H	2	Streaming access latency
98-99	0H	4	Streaming performance granularity
100-103	XXXXXH	8	Maximum user LBA for 48-bit addressing mode.
104	0H	2	Streaming transfer time - PIO
105	0001H	2	Max. number of 512-byte blocks of LBA Range Entries per DataSet Management command
106	4000H	2	Physical sector size per sector
107	0H	2	Inter-seek delay for ISO-7779 acoustic testing in microseconds
108-111	0000H	8	Unique ID
112-115	0H	8	Reserved
116	0H	2	Reserved
117-118	0H	4	Words per logical sector
119	0H	2	Features implemented (supported)
120	0H	2	Features implemented (enabled)
121-126	0H	12	Reserved
127	0H	2	Removable Media Status Notification feature set support
128	0021H	2	Security status
129-159	00H	62	Vendor specific
160	0H	2	CFA power mode 1
161-168	0H	16	Reserved for CFA
169	0001H	2	Data Set Management Trim attribute support
170-175	0H	12	Reserved for CFA
176-205	0H	60	Current media serial number
206	0H	2	SCT Command Transport
207-208	0H	4	Reserved
209	0H	2	Alignment of logical blocks within a physical block
210-211	0H	4	Write-Read-Verify Sector Count Mode 3
212-213	0H	4	Write-Read-Verify Sector Count Mode 2
214	0H	2	NV Cache Capabilities
215-216	0H	4	NV Cache Size in Logical Blocks
217	0001H	2	Nomial media rotational rate

Word Address	Default Value	Total Bytes	Data Field Type Information
218	0H	2	Reserved
219	0H	2	NV Cache Options
220	0H	2	Write-Read-Verify feature set
221	0H	2	Reserved
222	103FH	2	Transport major version number
223	0H	2	Transport minor version number
224-229	0H	12	Reserved
230-233	0H	8	Extended Number of User Addressable Sectors
234	0H	2	Min. number of 512-byte data blocks per DOWNLOAD MICROCODE command for mode 03H
235	0H	2	Max. number of 512-byte data blocks per DOWNLOAD MICROCODE command for mode 03H
236-254	0H	38	Reserved
255	XXXXH	2	Checksum

6. S.M.A.R.T. Feature Set

Cactus Technologies® -250SH Series SSDs supports S.M.A.R.T. attribute reporting. This following subcommands are supported when programmed into the Feature Register:

Value	Command	Value	Command
D0h	Read Data	D6h	SMART Write Log
D2h	Enable/Disable Autosave	D8h	Enable SMART operations
D4h	Execute OFF-LINE Immediate	D9h	Disable SMART operations
D5h	SMART Read Log	DAh	Return Status

6.1. S.M.A.R.T Data Structure

The Read Data commands returns 512 bytes of data in the following structure:

Bvte(s)	Description
0-1	Revision code
2-361	Data for attributes 1 - 30
362	Off-line data collection status
363	Self-test execution status byte
364-365	Total time in seconds to complete off-line data collection activities
366	Vendor specific
367	Off-line data collection capabilities
368-369	SMART capabilities
370	Error logging capabilities: bit7:11 – reserved: bit0: 1=device error logging supported
371	Vendor specific

Bvte(s)	Description
372	Short self-test routine recommended pollina time (in minutes)
373	Extended self-test routine recommended pollina time (in minutes)
374-510	Reserved
511	Data structure checksum

6.2. S.M.A.R.T Attribute Data Structure

Each attribute returned in bytes 2-361 of the 512-byte SMART data has the following format:

Byte(s)	Descriptions
0	Attribute ID
1 – 2	Flags
3	Current Value
4	Worst Value
5– 10	Attribute value
11	Reserved

6.3. S.M.A.R.T Attributes

The S.M.A.R.T attributes returned by the Read Data command are listed below:

Attribute ID	Attribute Name	Description
01h	Vendor Specific	
09h	Power-on hours	Total time of power-on state in hours
0Ch	Power cycle count	Number of power on/off cycles
0Dh	Vendor Specific	
AFh	Program Failure Block Count	Number of flash program failures: bits[23:0]: program fail count bits[47:24]: erase fail count
B8h	Initial bad block count	Number of initial bad blocks detected during firmware install

Attribute ID	Attribute Name	Description
BBh	Read fail block count	Uncorrectable read failure block count: bits[23:0]: read bad block count bits[47:24]: potential read bad block count
BEh	Temperature	Current device temperature in °C
C7h	SATA CRC error count	Number of SATA interface errors: bits[23:0]: CRC error count bits[47:24]: handshake error count
C8h	Total Write count	Total number of write commands issued
C9h	Total Read count	Total number of read commands issued
CAh	Vendor specific	
CCh	Vendor specific	
D1h	SSD life remaining	Approximate SSD life left (Max. PE cycle – avg. Erase count) / Max. PE cycle
D2h	Erase counts	Erase counts: bits[15:0]: min. erase count bits[31:16]: avg. erase count bits[47:32]: max. erase count
D5h	Max. PE count	Maximum Program/Erase count
E1h	Vendor specific	
E2h	Flush count	Flush command count: bits[23:0]: self flush count bits[47:24]: host flush count
E3h	Vendor specific	
E4h	Vendor specific	
E5h	Vendor specific	
E6h	Total Free Block	The current number of total free blocks count
F1h	Vendor specific	

6.4. S.M.A.R.T Execute Off-line Immediate (subcommand D4h)

This subcommand causes the device to start the off-line process for the requested mode and operation. The LBA Low register shall be set to specify the operation to be executed as follows:

LBA Low value	Description
00h	Execute SMART off-line data collection routine immediately
01h	Execute SMART short self-test routine immediately in off-line mode
02h	Execute SMART Extended self-test routine immediately in off-line mode
03h	Reserved
04h	Execute SMART Selective self-test routine immediately in off-line mode
40h	Reserved
7Fh	Abort off-line mode self-test routine
81h	Execute SMART short self-test routine immediately in captive mode
82h	Execute SMART Extended self-test routine immediately in captive mode
84h	Execute SMART Selective self-test routine immediately in captive mode
C0h	Reserved

Off-line mode: The device executes command completion before executing the specified routine. During execution of the routine the device will not set BSY nor clear DRDY. If the device is in the process of performing its routine and is interrupted by a new command from the host, the device will abort or suspend its routine and service the host within two seconds after receipt of the new command. After servicing the interrupting command, the device will resume its routine automatically or not start its routine depending on the interrupting command.

Captive mode: When executing self-test in captive mode, the device sets BSY to one and executes the specified self-test routine after receipt of the command. At the end of the routine, the device sets the execution result in the Self-test execution status byte and ATA registers and then executes the command completion. Taskfile registers will have return values as follows:

STATUS reg: Set ERR to one when self-test failed

ERR reg: Set ABRT to one when self-test failed

LBA LOW reg: Set to F4h when self-test failed

LBA HIGH reg: Set to 2Ch when self-test failed

6.5. S.M.A.R.T Read Log (subcommand D5h)

This command returns the specified log sector content to the host. LBA Low and Sector Count registers shall be set to specify the log sector and sector number to be written.

LBA Low value	Sector Count	Content	
00h	1	Log directory	Read only
01h	1	SMART error log	Read only
02h	51	Comprehensive SMART error log	Read only
03h	37	Extended Comprehensive SMART error log	Read only
06h	1	SMART self-test log	Read only
07h	1	Extended SMART self-test log	Read only
09h	1	Selective self-test log	R/W
10h	1	NCQ Error log	Read only
11h	1	SATA PHY event counter log	Read only
80h-9Fh	32	Host vendor specific	R/W
A0h	1	Reserved	Vendor specific

6.5.1. S.M.A.R.T Log Directory Structure

Byte(s)	Description
0-1	SMART log version (set to 01h)
2-3	Number of sectors in the log at log address 1
4-5	Number of sectors in the log at log address 2
6-509	Number of sector in the log at log addresses 3 to 254
510-511	Number of sectors in the log at log address 255

6.5.2. Self-test Log Structure

Byte(s)	Description
0-1	Log version

Byte(s)	Description
2+n*24	Self-test number
3+n*24	Self-test status
4+n*24 - 5+n*24	timestamp
6+n*24	Self-test failure checkpoint
7+n*24 - 10+n*24	LBA of first failure
11+n*24 - 25+n*24	Vendor specific
----	----
506-507	Vendor specific
508	Self-test log pointer
509-510	Reserved
511	Checksum

n is 0 through 20.

The data structure contains the descriptor of the Self-test that the device has performed. Each descriptor is 24 bytes long and the self-test data structure is capable to contain up to 21 descriptors. After 21 descriptors has been recorded, the oldest descriptor will be overwritten with the new descriptor. The self-test log pointer points to the most recent descriptor. When there is no descriptor, the value is 0. When there are descriptor(s), the value is 1 through 21.

6.5.3. SelectiveSelf-test Log Structure

Byte(s)	Description	Read/Write
0-1	Log version	R/W
2-9	Starting LBA for test span 1	R/W
10-17	Ending LBA for test span 1	R/W
18-25	Starting LBA for test span 2	R/W
26-33	Ending LBA for test span 2	R/W
34-41	Starting LBA for test span 3	R/W
42-49	Ending LBA for test span 3	R/W
50-57	Starting LBA for test span 4	R/W
58-65	Ending LBA for test span 4	R/W
66-73	Starting LBA for test span 5	R/W
74-81	Ending LBA for test span 5	R/W

Byte(s)	Description	Read/Write
82-337	Reserved	--
338-491	Vendor specific	--
492-499	Current LBA under test	Read
500-501	Current span under test	Read
502-503	Feature flags R/W	R/W
504-507	Vendor specific	--
508-509	Selective self test pending time	R/W
510	Reserved	--
511	Checksum	R/W

6.6. S.M.A.R.T Write Log Sector (subcommand D6h)

This subcommand writes 512 bytes of data to the specified log sector. LBA Low and Sector Count registers shall be set to specify the log address and sector number to be written.

6.7. S.M.A.R.T Enable Operations (subcommand D8h)

This subcommand enables access to all SMART capabilities. Prior to issuance of this subcommand, SMART attributes are not being monitored. The state of SMART, whether enabled or disabled, is preserved across power cycling.

6.8. S.M.A.R.T Disable Operations (subcommand D9h)

This subcommand disables all SMART capabilities. After receipt of this subcommand, all other SMART commands other than SMART Enable operations will be aborted and error code returned. SMART attributes that are being monitored while SMART operation is enabled will be saved. If SMART operation is enabled subsequently, the attribute values will be updated accordingly.

6.9. S.M.A.R.T Return Status (subcommand DAh)

This subcommand returns the pass/fail status of the device to the host.

Appendix A. Ordering Information

Model KDXY-250SH

Where: X is drive capacities:

2T ----- 2TB
4T ----- 4TB
8T ----- 8TB (std. Temp. only)

Where: Y is temperature grade:

blank ----- standard temp.
I ----- extended temp.

Example:

- (1) 2TB 2.5" SSD ----- KD2TF-250SH
- (2) 4TB 2.5" SSD extended temp. ----- KD4TFI-250SH

Appendix B. Technical Support Services

B.1. Direct Cactus Technologies® Technical Support

Email: tech@cactus-tech.com

Appendix C.Cactus Technologies® Worldwide Sales Offices

Email: sales@cactus-tech.com

Email: americas@cactus-tech.com

Appendix D. Limited Warranty

I. WARRANTY STATEMENT

Cactus Technologies® warrants its Commercial Grade products only to be free of any defects in materials or workmanship that would prevent them from functioning properly for two years from the date of purchase or when rated TBW is exceeded, whichever occurs first. This express warranty is extended by Cactus Technologies® Limited to customers of our products.

II. GENERAL PROVISIONS

This warranty sets forth the full extent of Cactus Technologies® responsibilities regarding the Cactus Technologies® Commercial Grade Flash Storage Products. Cactus Technologies®, at its sole option, will repair, replace or refund the purchase price of the defective product. Cactus Technologies® guarantees our products meet all specifications detailed in our product manuals. Although Cactus Technologies® products are designed to withstand harsh environments and have the highest specifications in the industry, they are not warranted to never have failure and Cactus Technologies® does not warranty against incidental or consequential damages. Accordingly, in any use of products in life support systems or other applications where failure could cause injury or loss of life, the products should only be incorporated in systems designed with appropriate redundancy, fault tolerant or backup features.

III. WHAT THIS WARRANTY COVERS

For products found to be defective, Cactus Technologies® will have the option of repairing, replacing or refunding the purchase price the defective product, if the following conditions are met:

- A. The defective product is returned to Cactus Technologies® for failure analysis as soon as possible after the failure occurs.
- B. An incident card filled out by the user, explaining the conditions of usage and the nature of the failure, accompanies each returned defective product.
- C. No evidence is found of abuse or operation of products not in accordance with the published specifications, or of exceeding maximum ratings or operating conditions.

All failing products returned to Cactus Technologies® under the provisions of this limited warranty shall be tested to the product's functional and performance specifications. Upon confirmation of failure, each product will be analyzed, by whatever means necessary, to determine the root cause of failure. If the root cause of failure is found to be not covered by the above provisions, then the product will be returned to the customer with a report indicating why the failure was not covered under the warranty.

This warranty does not cover defects, malfunctions, performance failures or damages to the unit resulting from use in other than its normal and customary manner, misuse, accident or neglect; or improper alterations or repairs. Cactus Technologies® Limited may repair or replace, at its discretion, any product returned by its customers, even if such product is not covered under warranty, but is under no obligation to do so.

IV. RECEIVING WARRANTY SERVICE

According to Cactus Technologies® warranty procedure, defective product should be returned only with prior authorization from Cactus Technologies® Limited. Please contact Cactus Technologies® Customer Service department (tech@cactus-tech.com) with the following information: product model number and description, nature of defect, conditions of use, proof of purchase and purchase date. If approved, Cactus Technologies® will issue a Return Material Authorization or Product Repair Authorization number and shipping instructions.